



EGYPTIAN COMPANY
FOR ENGINEERING
AND METAL INDUSTRIES

ecemi-alu.com

Company Catalogue



EXTRUDING THE FUTURE

Content

- 01 About
 - 02 Insightful Vision
 - 03 Road Map and Next Steps
 - 04 Exporting
 - 05 Industries
 - 06 Extruded Profiles
 - 07 Extrusion Stamps
 - 08 Architectural Systems
-



ABOUT

CHANGING METAL INDUSTRIES

The Egyptian company already extruded many of the famous systems in the Egyptian market.

The company follows international quality standards in line with the standard specifications set by the Egyptian General Organization for Standardization and Quality.

Accordingly, the company tends to extrude various other profiles in the architectural field, as well as standard profiles and industrial sectors for several fields. The Egyptian company is ready to start exporting the profiles to all markets Arabian, African and European countries.



Insightful Vision

To lead the industry aluminum and be the first and most reliable supplier for extruded Aluminum in the MENA region, by generating sustainable growth; creating long-lasting quality, satisfying all requirements with high efficiency, proudly engraving "Made in Egypt" on our high-quality products, and stamping our footprint around the world.



Road Map And Next Steps

Our goal is to become a high-value supplier for our partners by doubling our annual production and increasing our export rate to 72% of our annual extruded aluminum output. At ECEMI, we are actively expanding our production lines and installing a new, state-of-the-art production line. This expansion allows us to leverage modern techniques and consistently deliver high-quality, innovative products to meet the evolving needs of our global clients.



Exporting

ECEMI stands as one of the largest extrusion exporters in Egypt, recognized for its strong reputation within the Middle Eastern aluminum industry. We serve an extensive global customer base, including markets across Germany, France, Switzerland, North Africa and beyond.

EUROPE

AFRICA

NORTH AMERICA

MIDDLE EAST



Industries







We're the supplier of a wide range of all aluminum shapes like tubes, corner and U shapes to different residential, administrative, commercial and more industries.

- SUPPORTING SERVICES
- RESIDENTIAL
- ADMINISTRATIVE & COMMERCIAL
- COMMUNITY
- TOURISM
- INDUSTRIAL

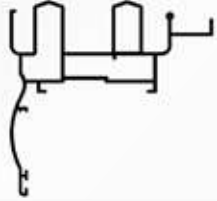
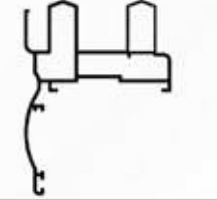

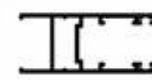

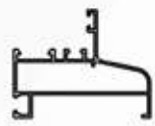





SLIDING EG 70

Cood	DESCRIPTION	PROFILE	WEIGHT Kg/ml.
EG 6621	FRAME WITH ARCTRAVE		1.436
EG 6601	FRAME WITH ARCTRAVE		1.260
EG 6602	SASH FOR SINGLE GLAZING		0.780
EG 6607	SASH FOR DOUBLE GLAZING		0.696
EG 6600	FRAME		0.980
EG 6603	HOOK		0.369
EG 6648	FIXED FRAME		0.830
EG 6613	SINGLE DRRIVER FOR SCREENS		0.146



SLIDING EG 70

Cood	DESCRIPTION	PROFILE	WEIGHT Kg/ml.
EG 6605	ADJOINING PROFILE		0.175
EG 5625	ARCTRAVE		0.281
EG 5626	ARCTRAVE		0.280
EG 6606	SASH FOR SCREENS		0.500
EG 6006	SASH FOR SCREENS		0.570
EG 9609	HOOK		0.154
EG 9914	CAVER		0.084



SLIDING EG 70

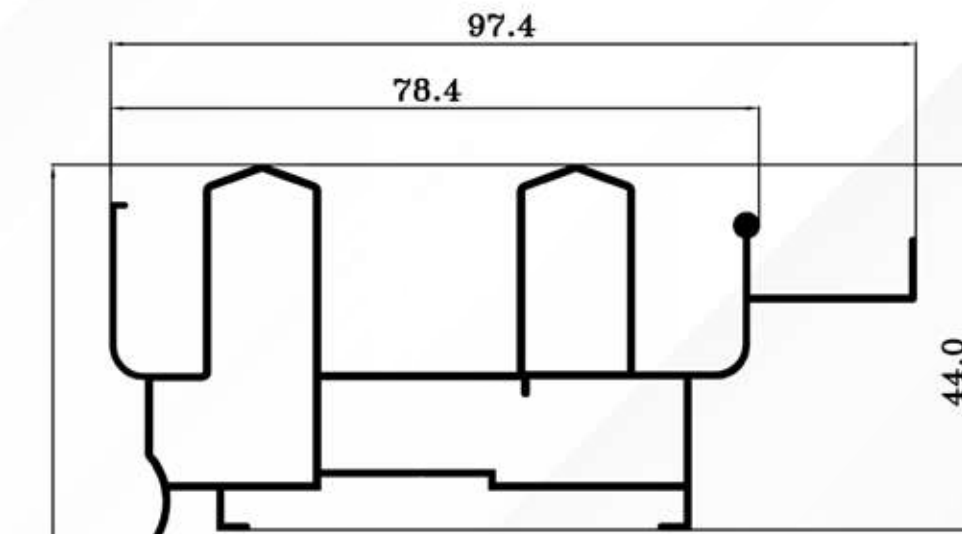

EG 6621 1.436 Kg/ml.

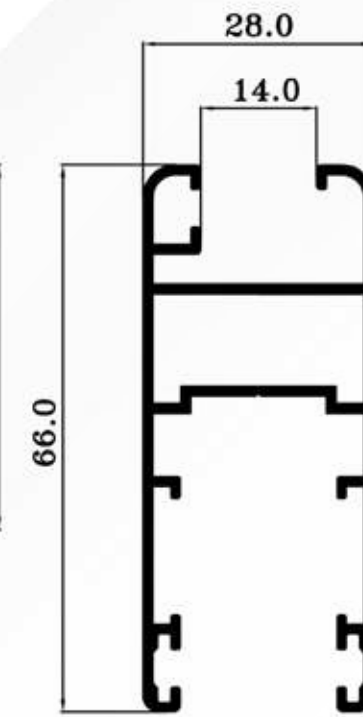

EG 6602 0.780 Kg/ml.

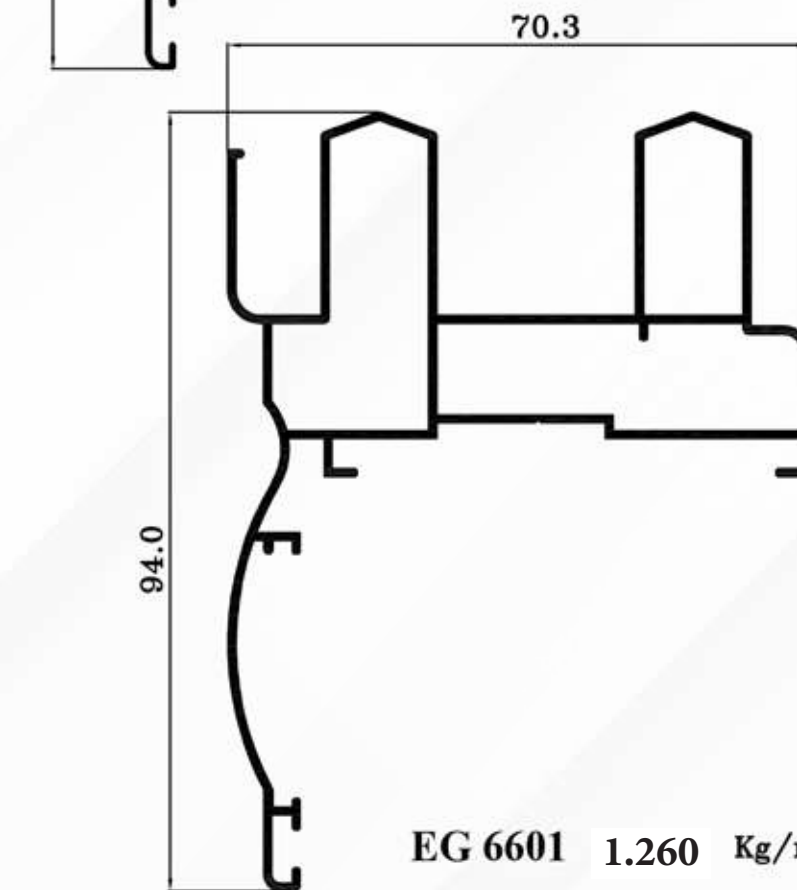

EG 6601 1.260 Kg/ml.

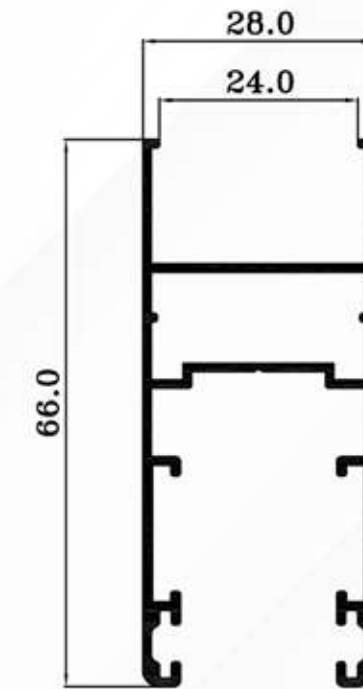

EG 6607 0.696 Kg/ml.



SLIDING EG 70

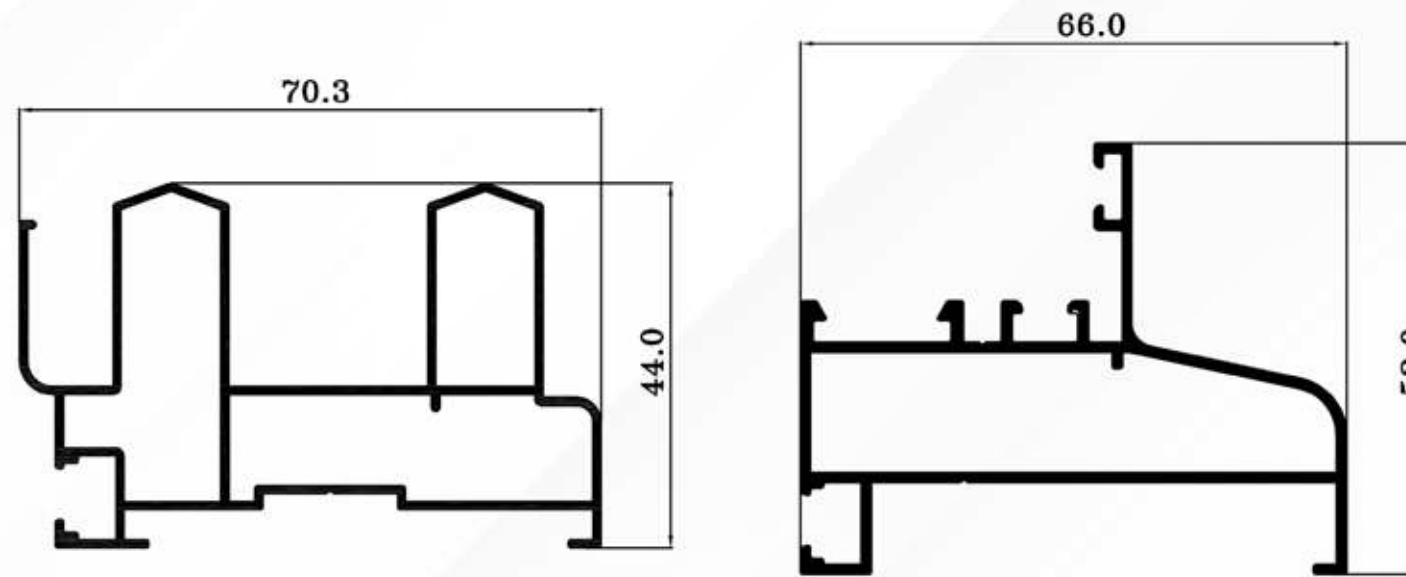

EG 6600 0.822 Kg/ml.

EG 6648 0.369 Kg/ml.

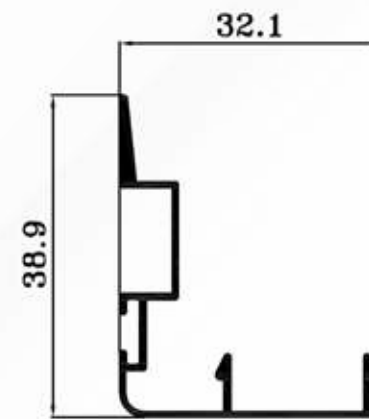

EG 6603 0.369 Kg/ml.

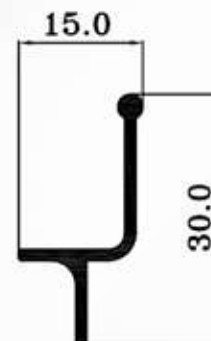

EG 6613 Kg/ml.

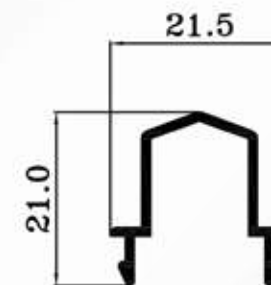

EG 6605 0.175 Kg/ml.



SLIDING EG 70

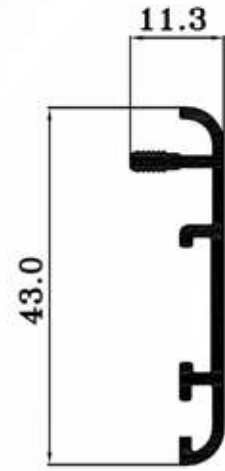

EG 5625 0.281 Kg/ml.

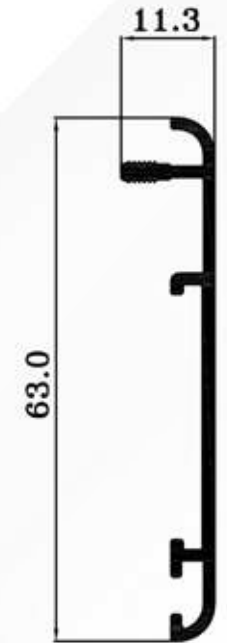

EG 5626 0.280 Kg/ml.

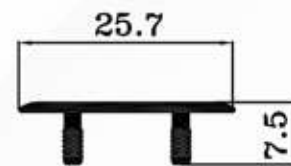

EG 9609 0.154 Kg/ml.

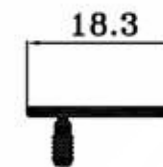

EG 9914 0.084 Kg/ml.

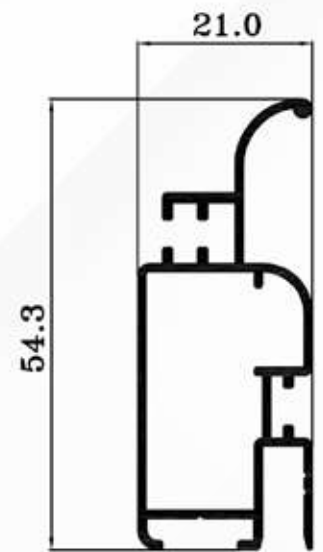

EG 6006 0.570 Kg/ml.

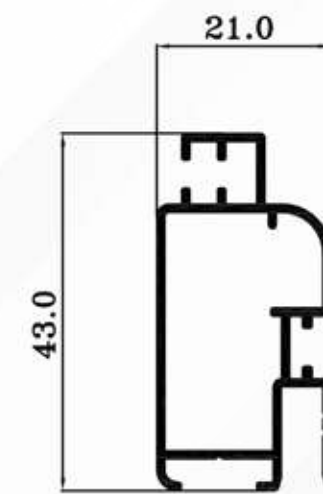

EG 6606 0.500 Kg/ml.



SLIDING EG 70

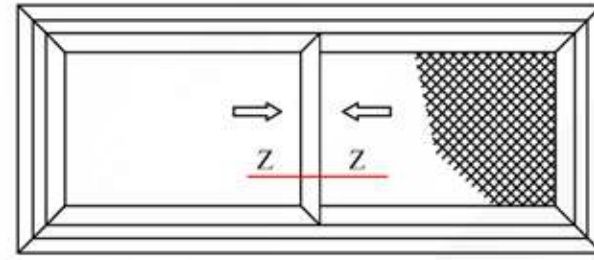

SECTION Z-Z



SLIDING EG 70

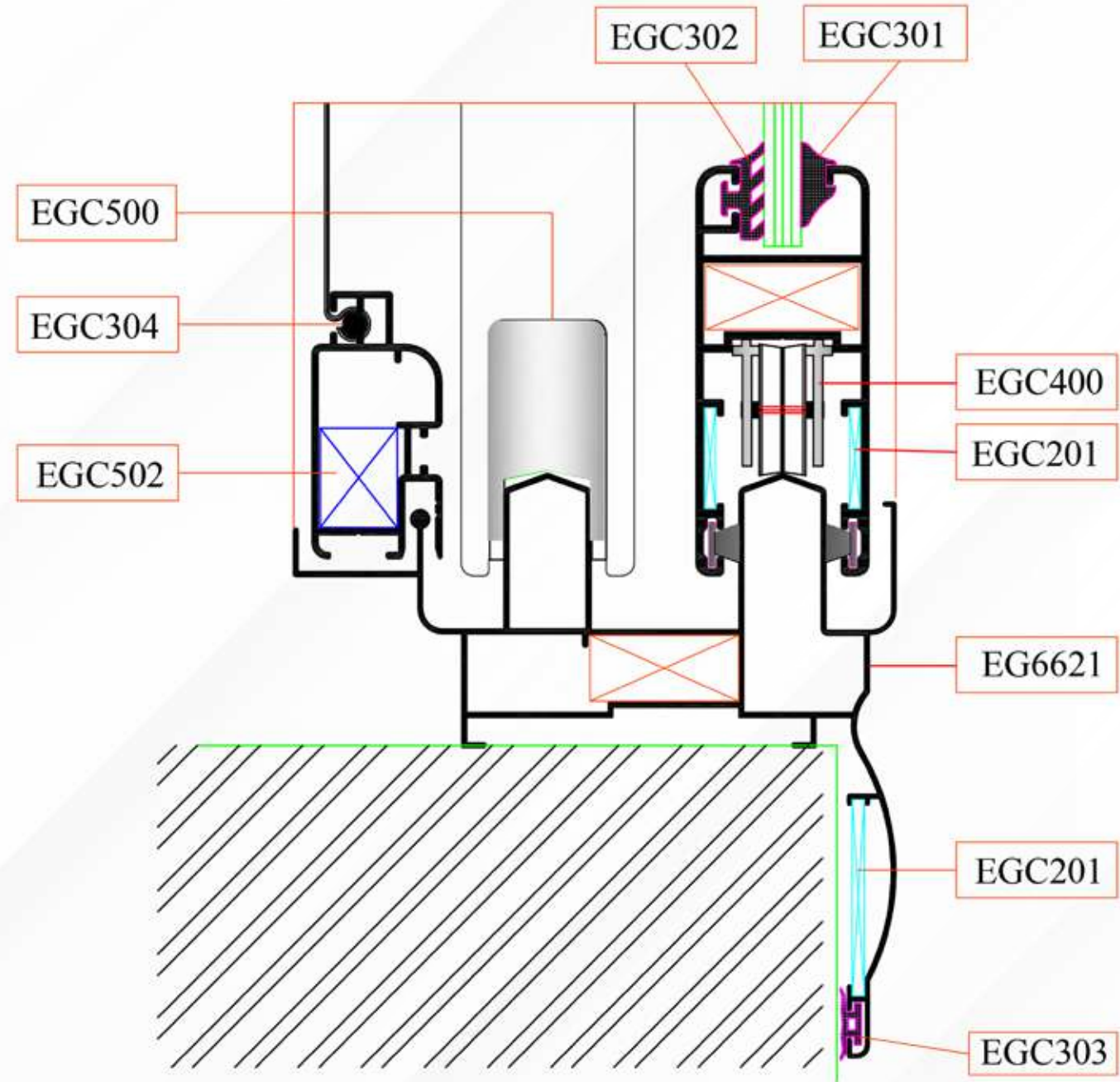
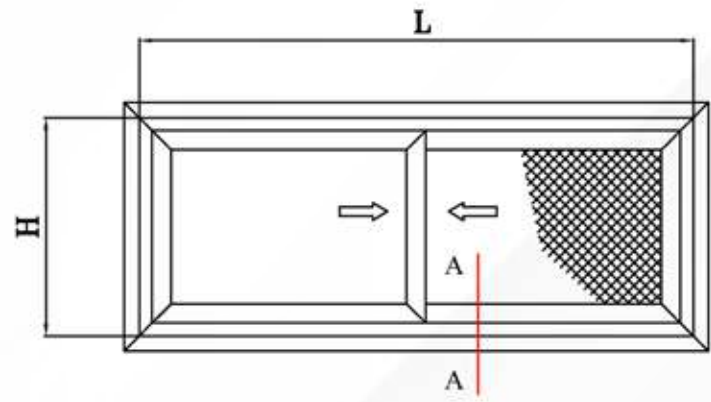

SECTION A-A



SLIDING EG 70

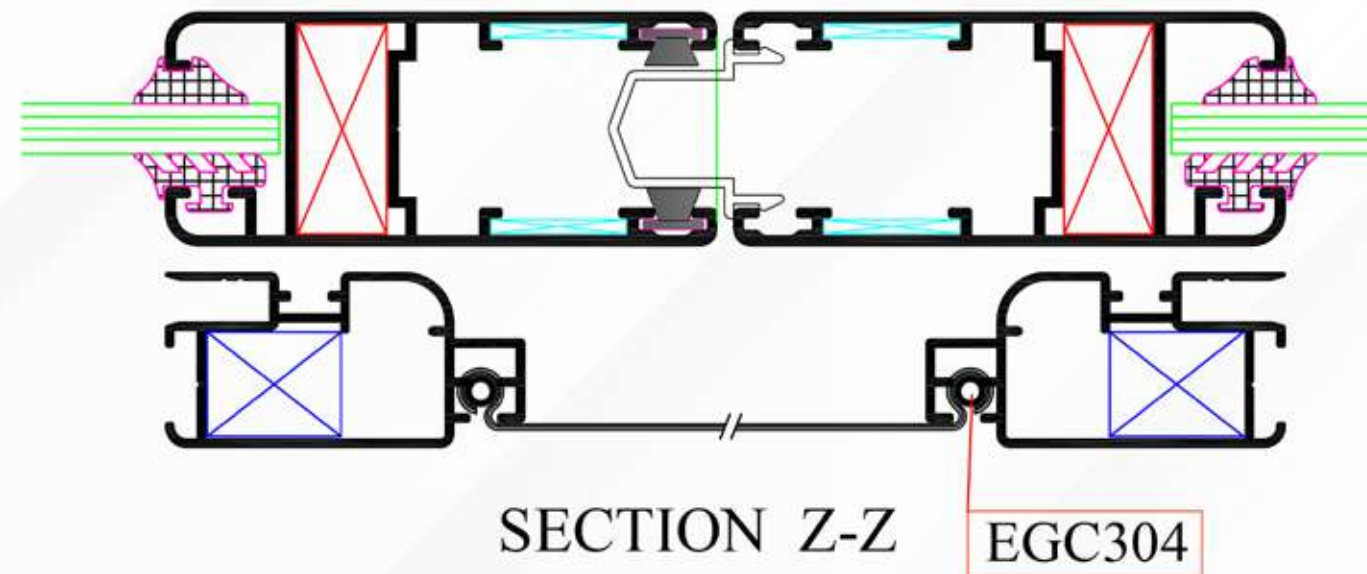
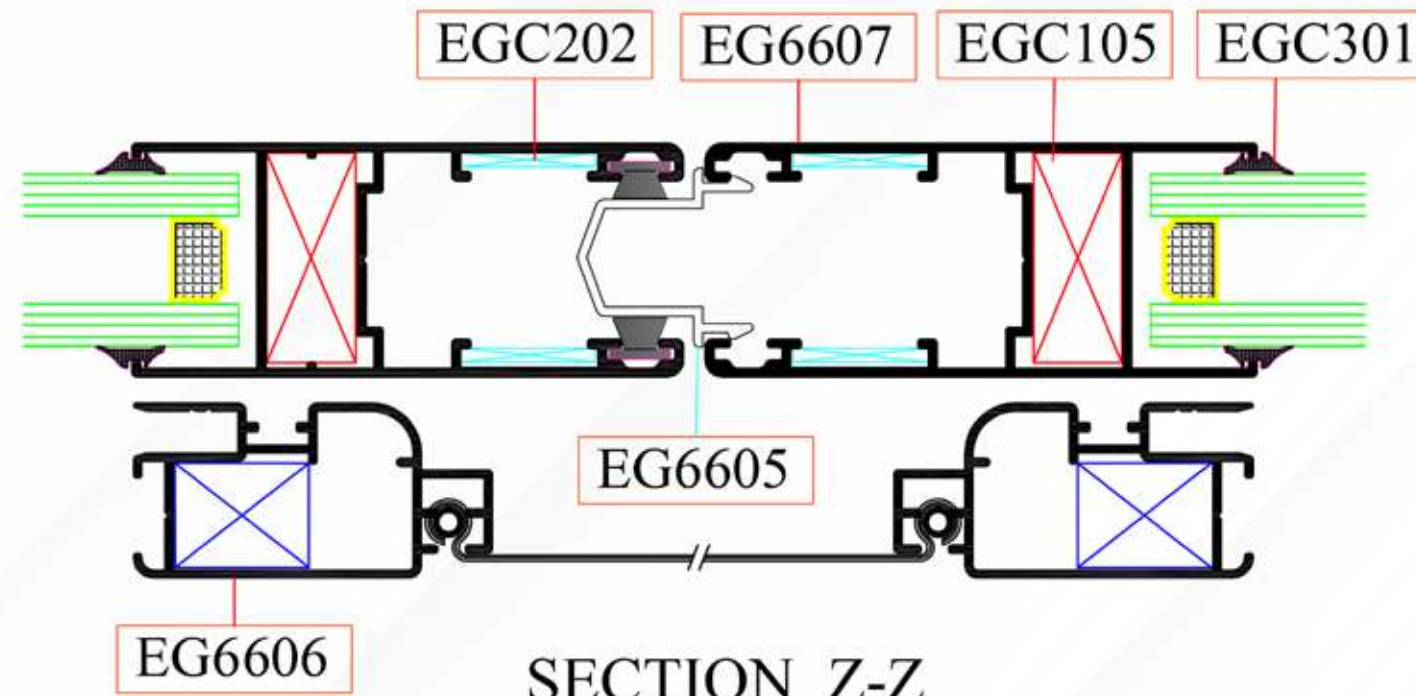
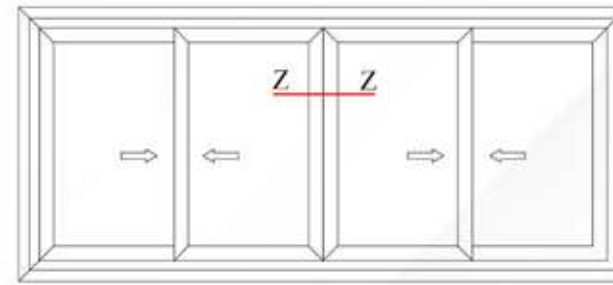



SLIDING EG 70

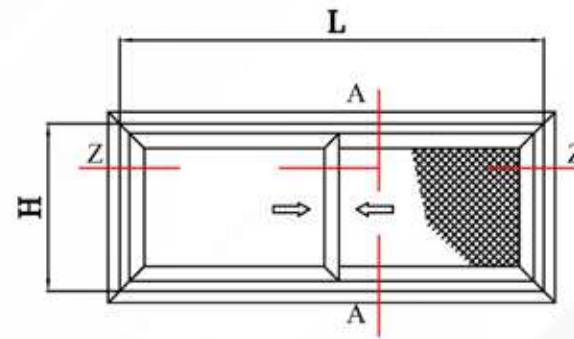

SECTION A-A

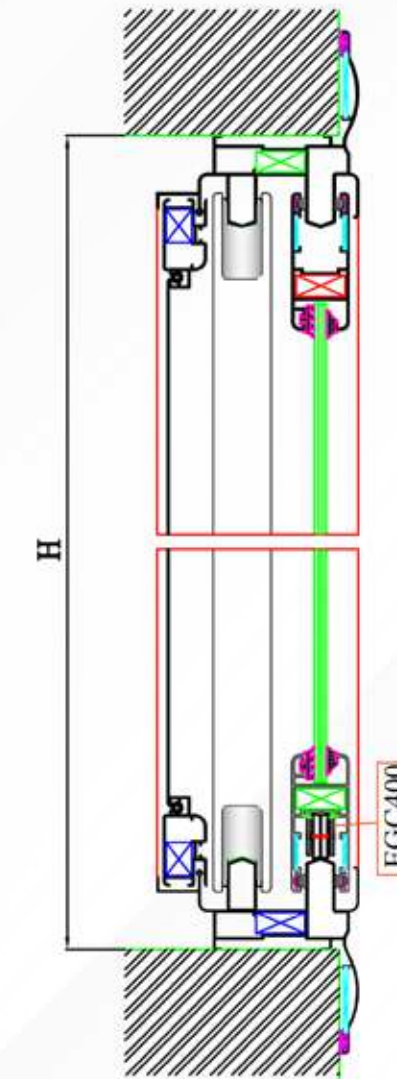

PROFILE No.	QTY.	CUTTING LENGTH (C.m)	CUTTING ANGLE	PROFILE DWG.
EG6621	2	$H+10$	45	
EG6621	2	$L+10$	45	
EG6602	2	$\frac{L-0.12}{2}$	45	
EG6602	2	$H-6.6$	45	
EG6603	2	$H-6.6$	90	
EG6606	2	$L/2$	45	
EG6606	2	$H-7$	45	

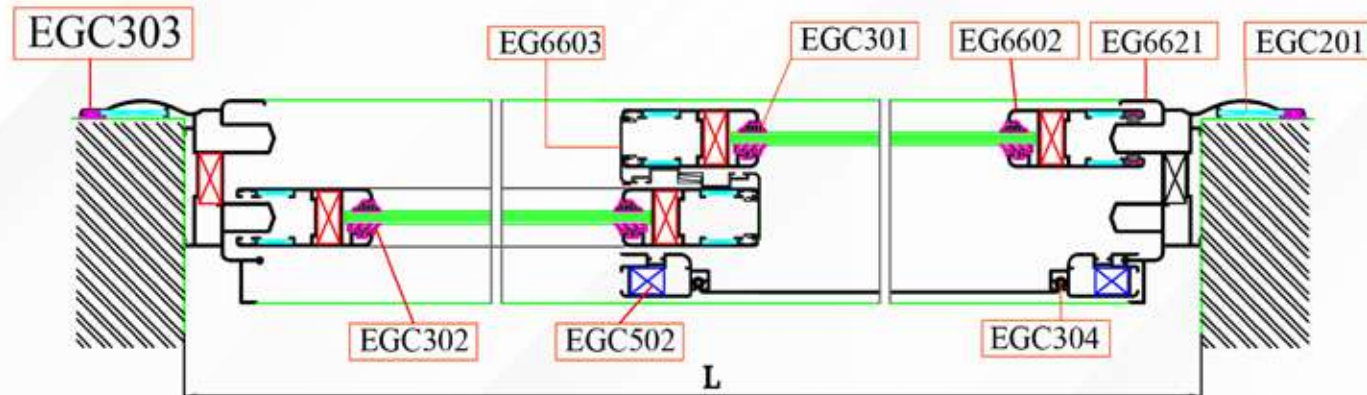

SECTION Z-Z



SLIDING EG 70

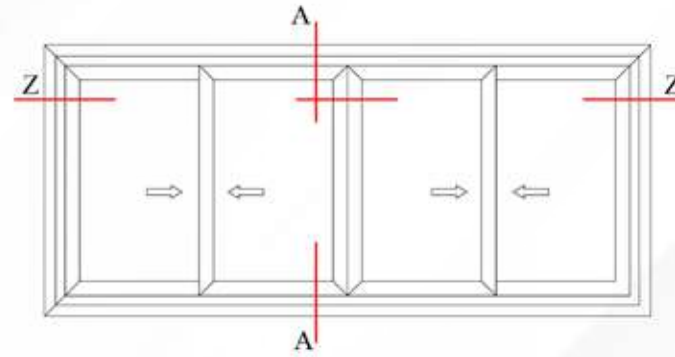

SECTION A-A

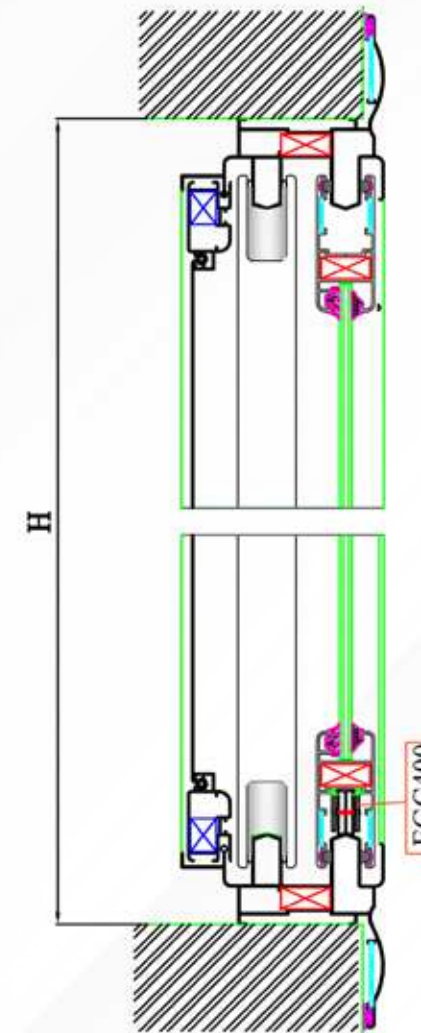



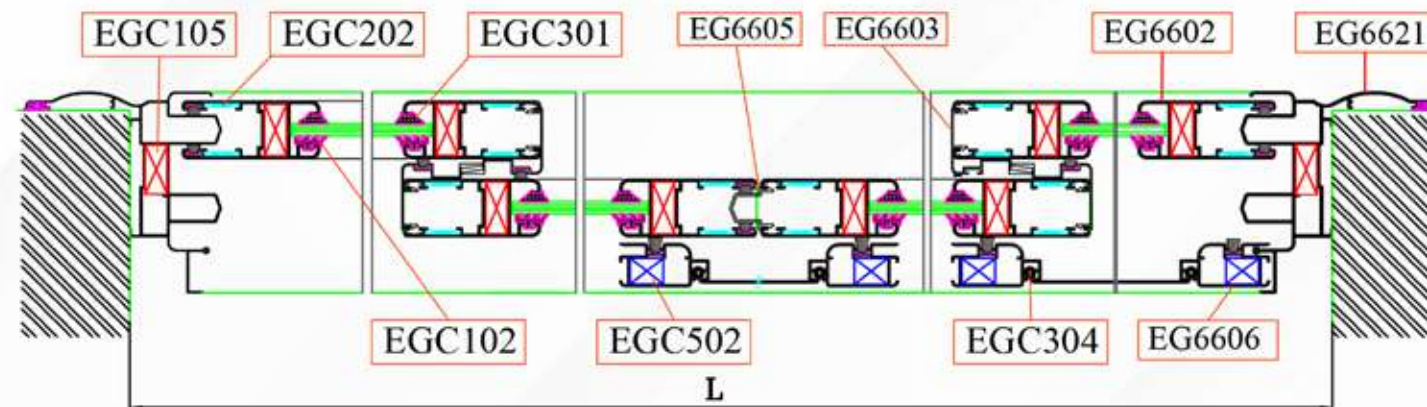

PROFILE No.	QTY.	CUTTING LENGTH (C.m)	CUTTING ANGLE	PROFILE DWG.
EG6601	2	$H+10$	45	
EG6601	2	$L+10$	45	
EG6602	4	$\frac{L-6.3}{4}$	45	
EG6602	4	$H+6.6$	45	
EG6603	4	$H+6.6$	90	
EG6605	1	$H+6.6$	90	
EG6606	4		45	
EG6606	4		45	



SECTION Z-Z

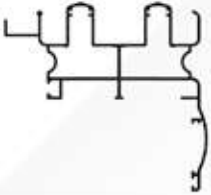
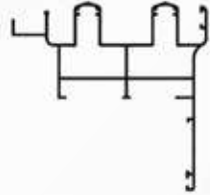
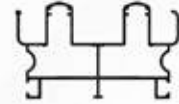
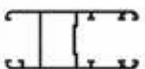
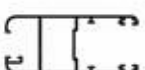

SLIDING EG 100

Cood	DESCRIPTION	PROFILE	WEIGHT Kg/ml.
EG 9642	FRAME WITH ARCTRAVE		1.485
EG 9652	FRAME WITH ARCTRAVE		1.512
EG 9601	FRAME		1.540
EG 9607	SASH FOR DOUBLE GLAZING		0.875
EG 9602	SASH FOR SINGLE GLAZING		0.904
EG 9603	HOOK		0.507
EG 9605	ADJOINING PROFILE		0.334
EG 9606	SASH FOR DOUBLE GLAZING		0.805



SLIDING EG 100

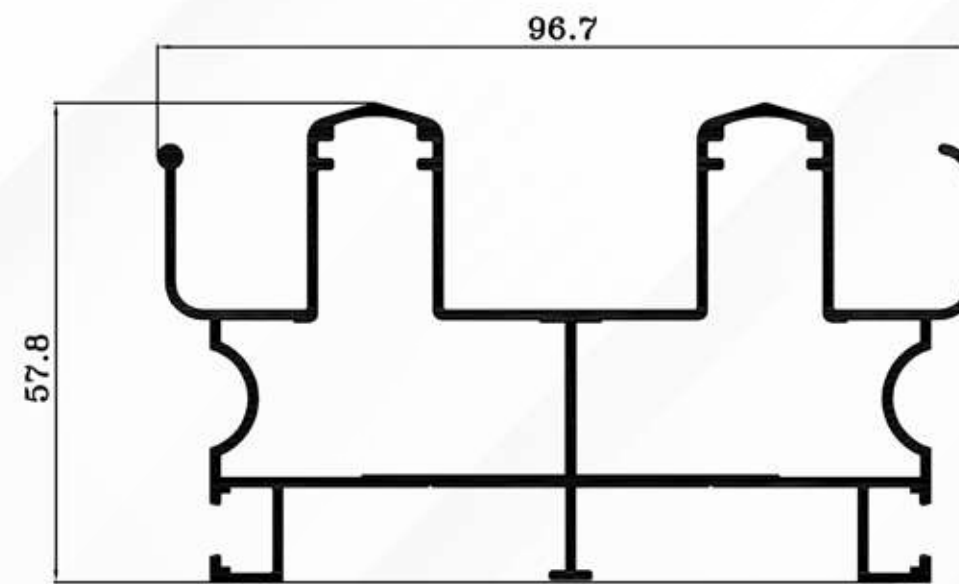
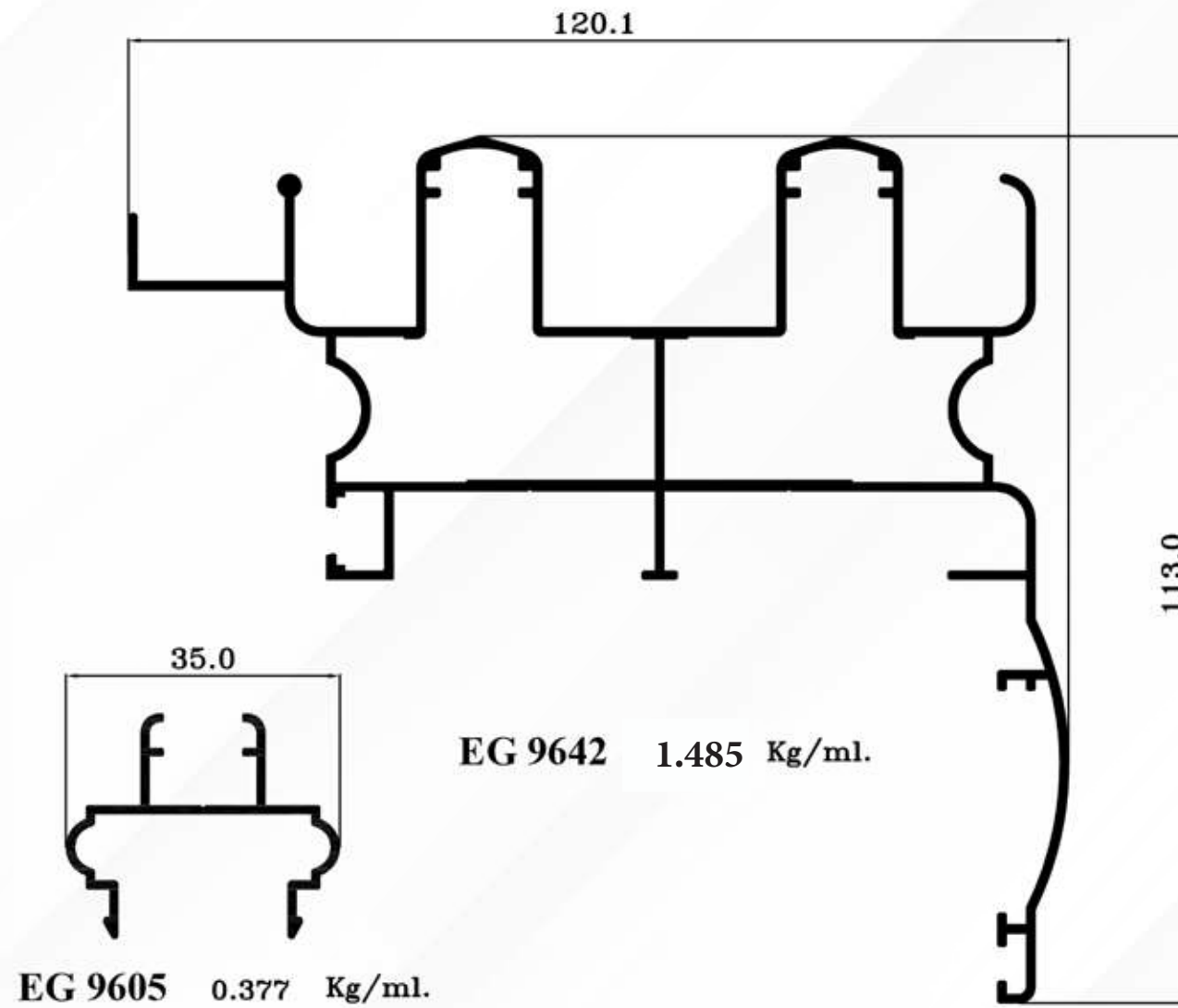

EG 9601 1.540 Kg/ml.



SLIDING EG 100

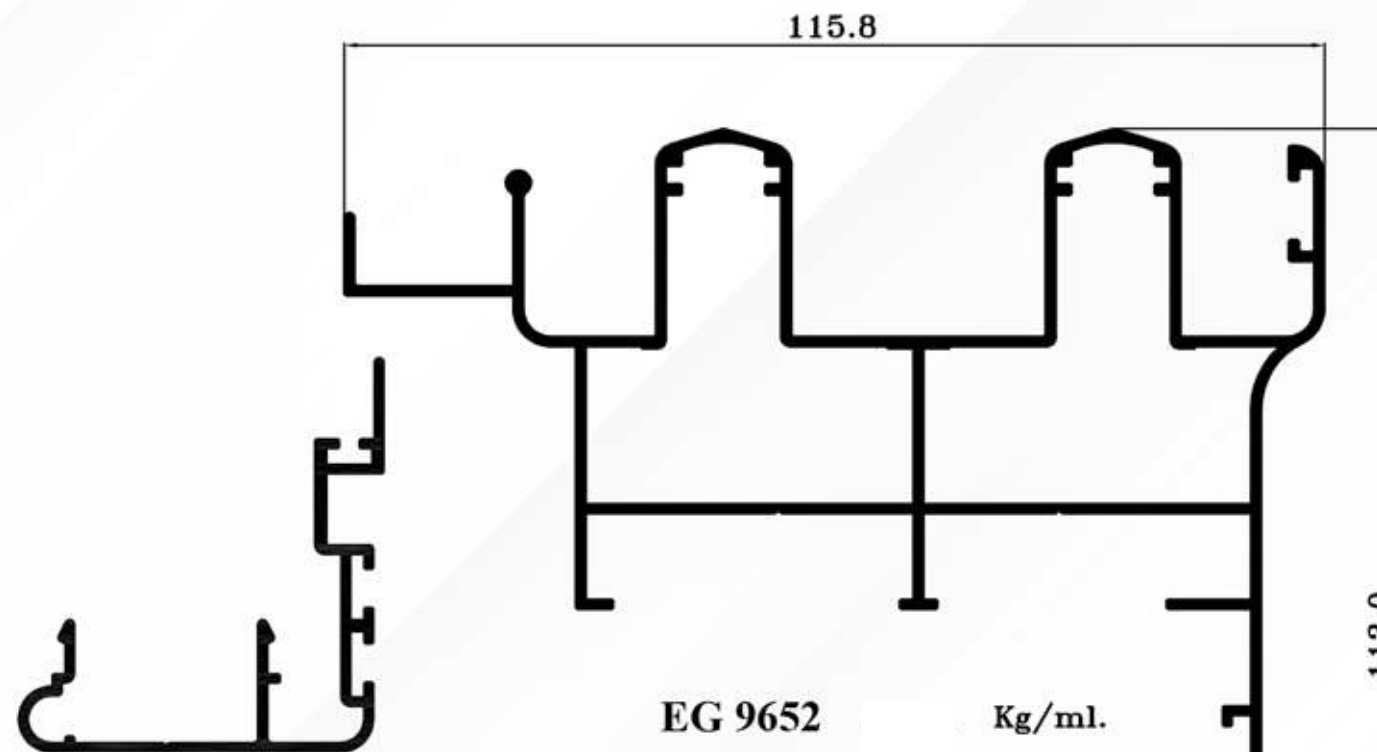

EG 9652 Kg/ml.

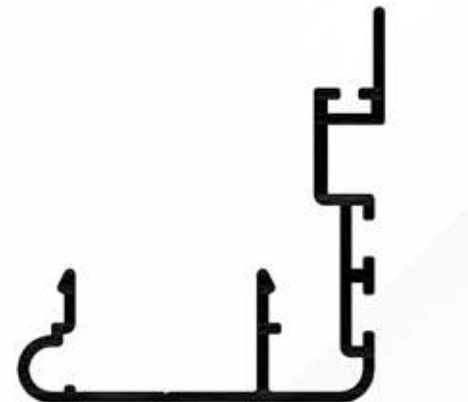

EG 9603 0.466 Kg/ml.

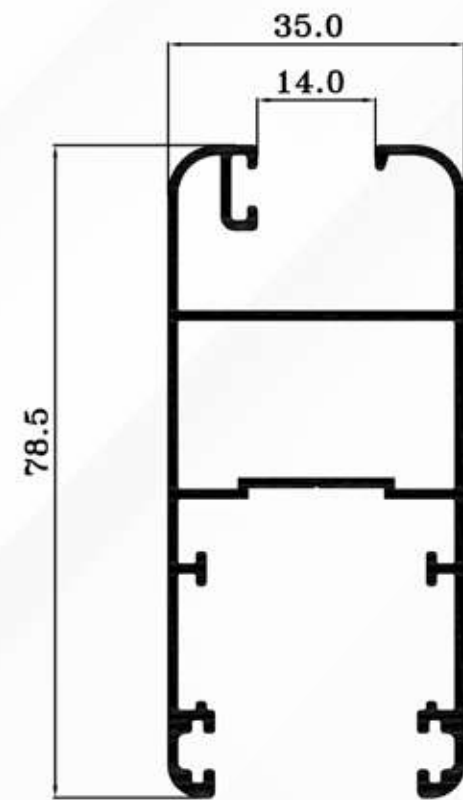

EG 9602 0.904 Kg/ml.

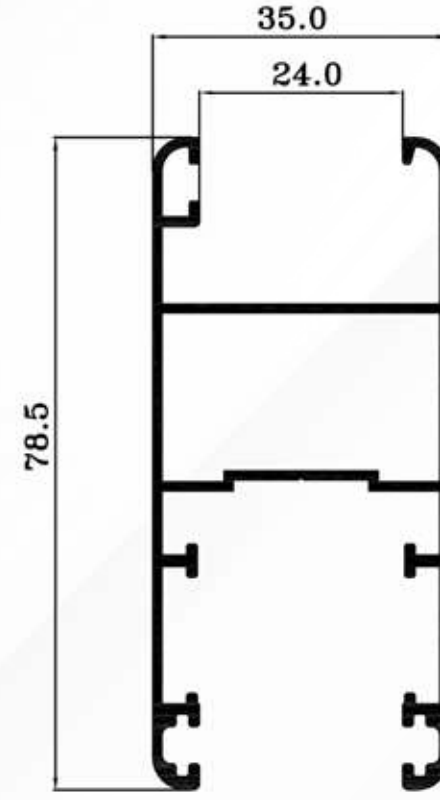

EG 9607 0.875 Kg/ml.



SLIDING EG 100

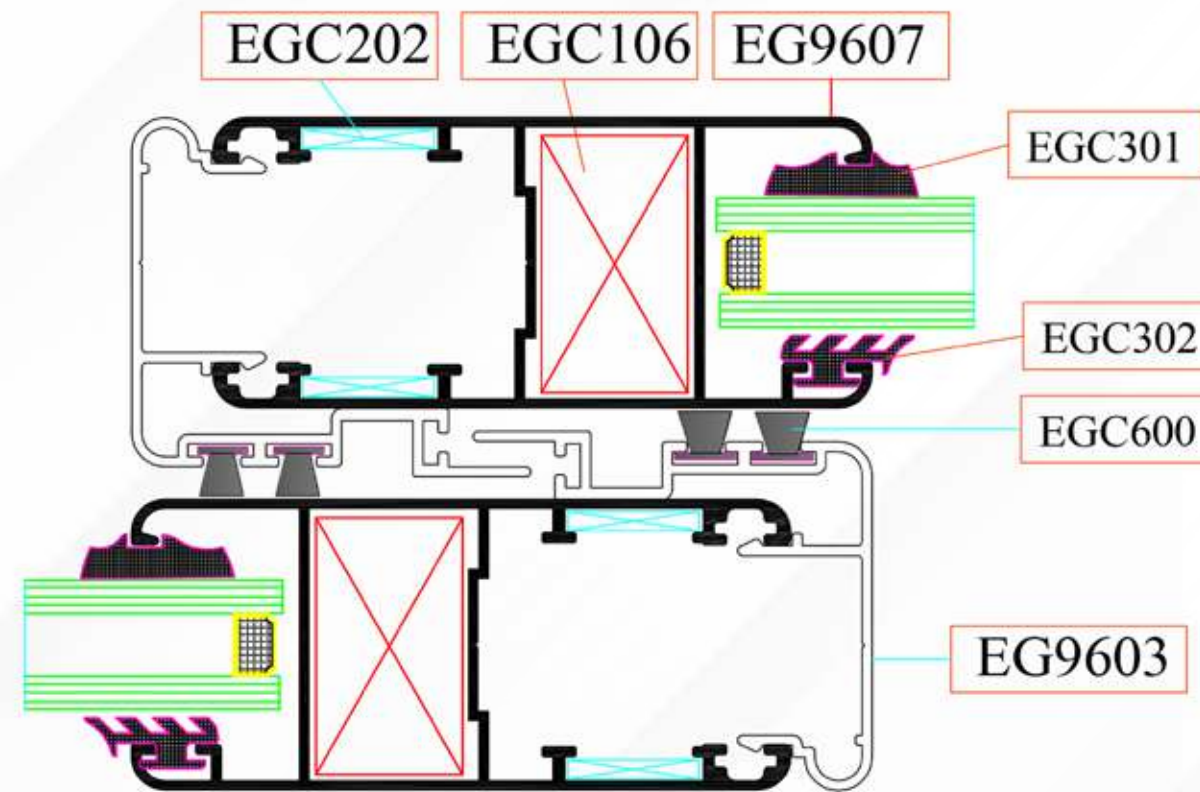
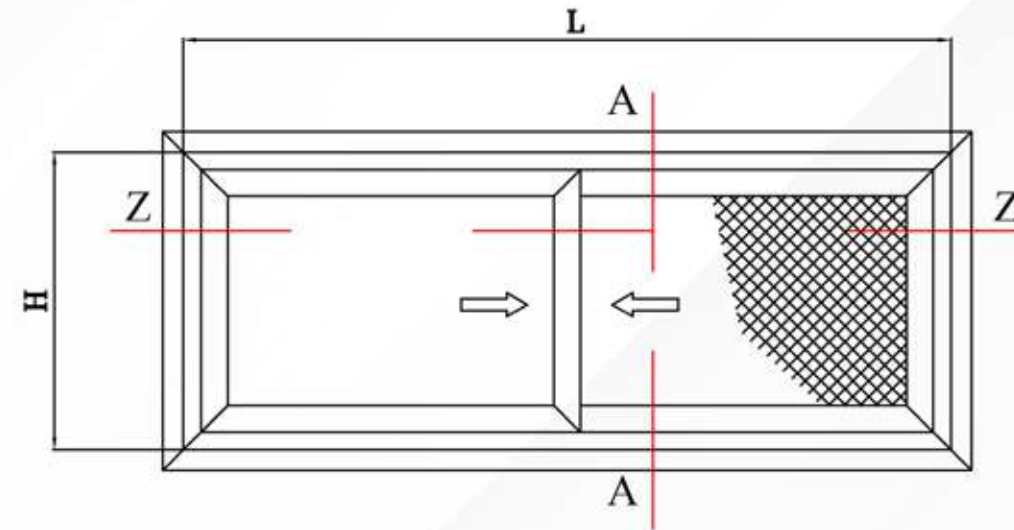

SECTION Z-Z



SLIDING EG 100

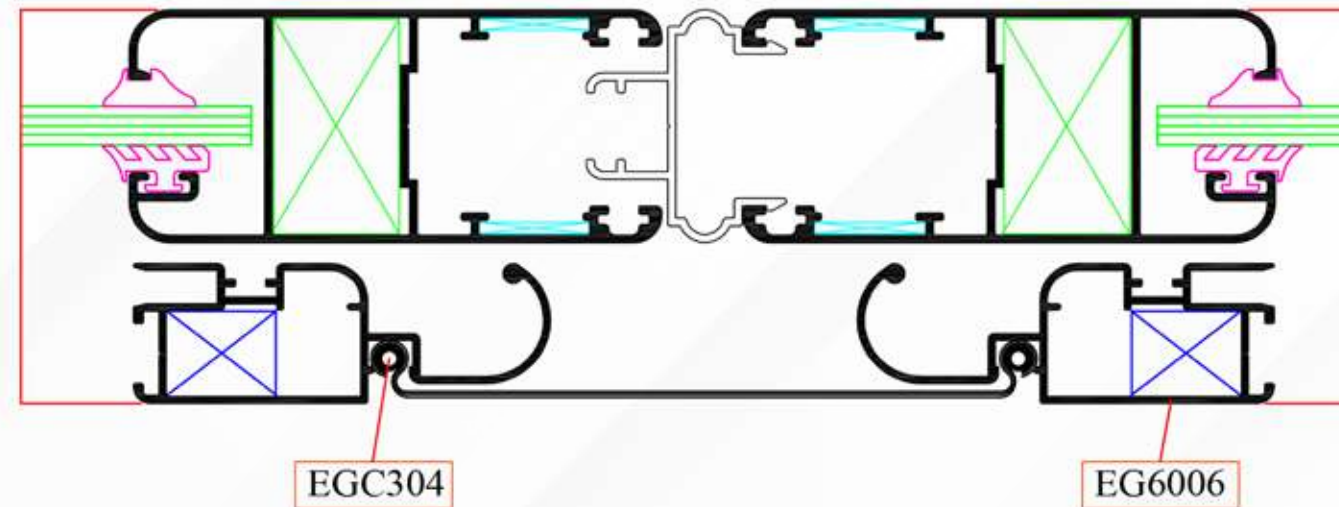
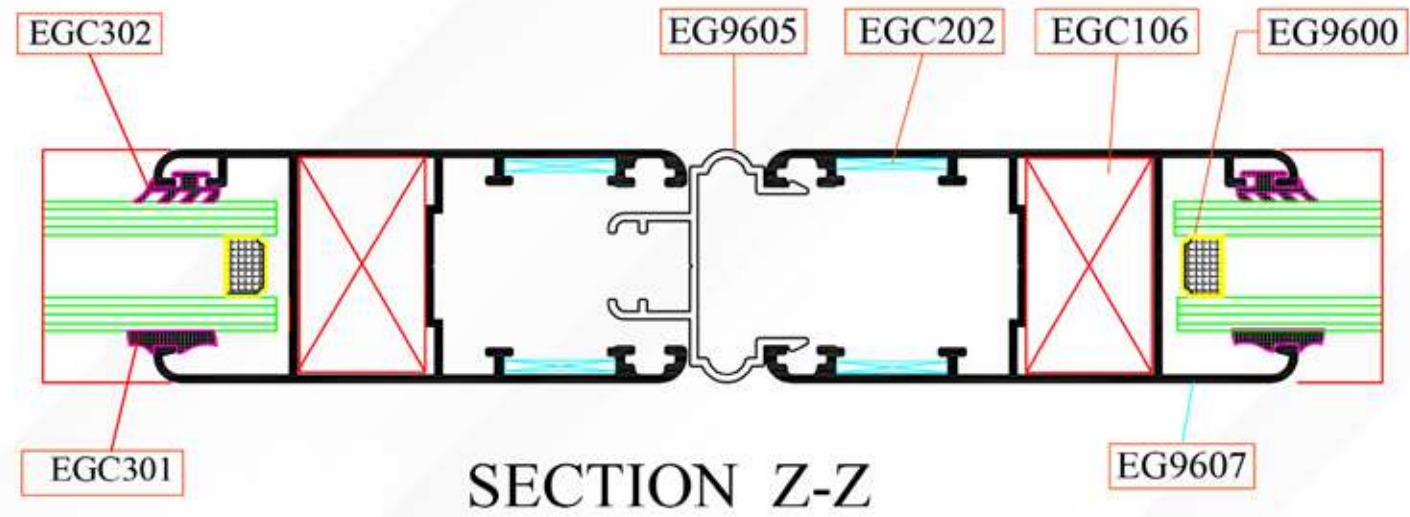
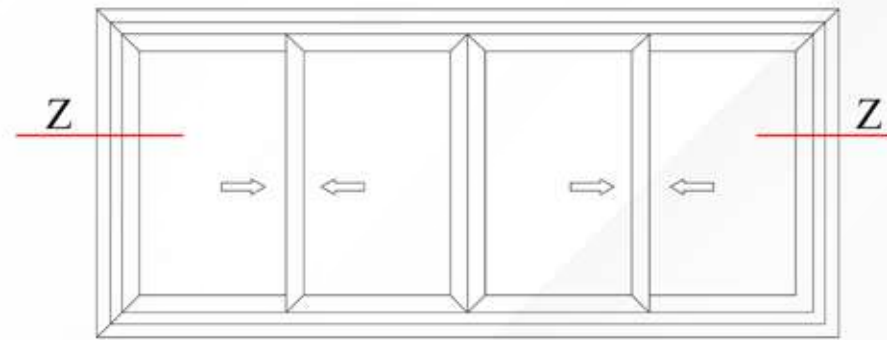



SLIDING EG 100

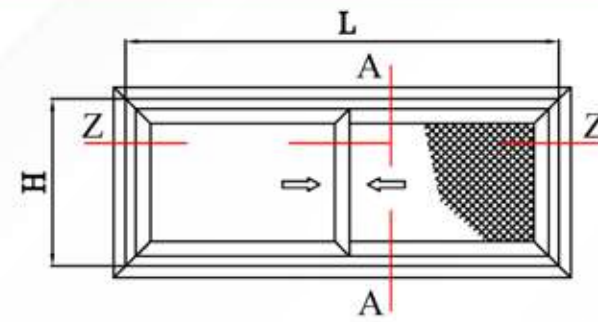

PROFILE No.	QTY.	CUTTING LENGTH (C.m)	CUTTING ANGLE	PROFILE DWG.
EG9642	2	$H+10$	45	
EG9642	2	$L+10$	45	
EG9602	4	$\frac{L-0.15}{2}$	45	
EG9602	4	$H-9.4$	45	
EG9603	2	$H-9.4$	90	
EG9606	2	$L/2$	45	
EG9606	2	$H-9.4$	45	

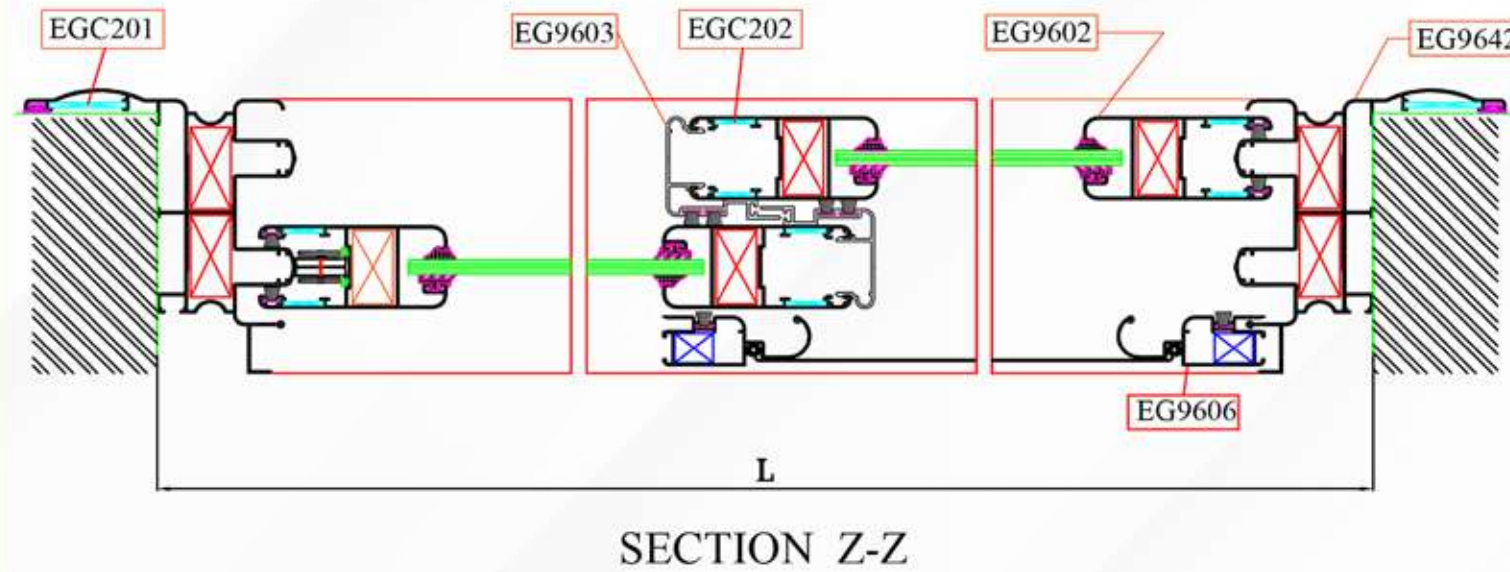
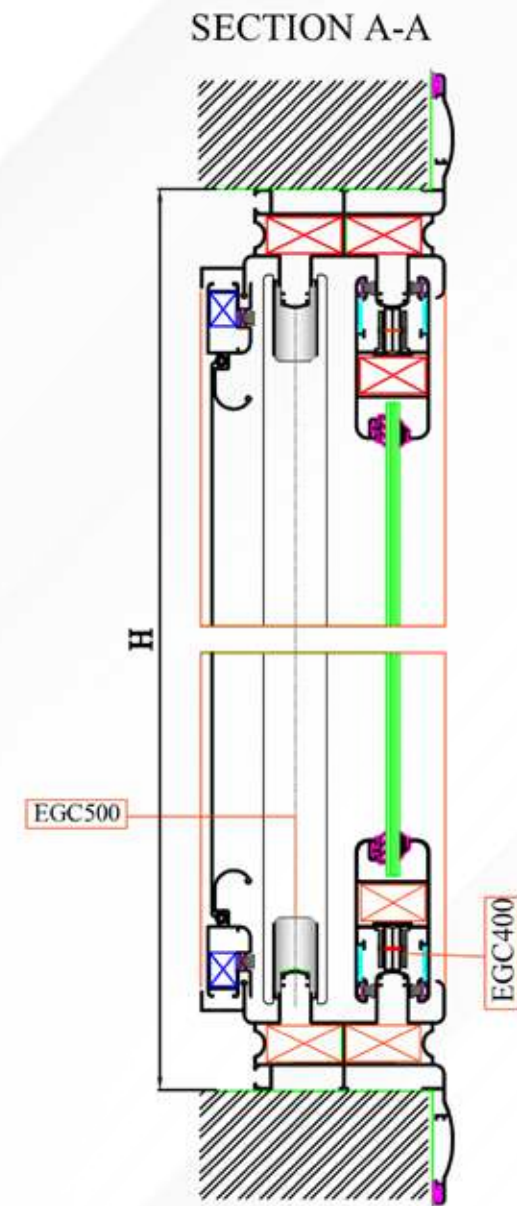



SLIDING EG 100

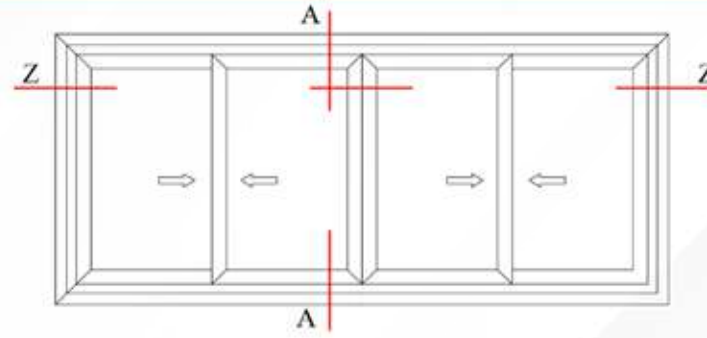

PROFILE No.	QTY.	CUTTING LENGTH (C.m)	CUTTING ANGLE	PROFILE DWG.
EG9642	2	$H+10$	45	
EG9642	2	$L+10$	45	
EG9602	8	$\frac{L+3}{4}$	45	
EG9602	8	$H-9.4$	45	
EG9603	4	$H-9.4$	90	
EG9606	1	$H-9.4$	90	
EG9606	4	$L/2$	45	
EG9606	4	$H-9.4$	45	

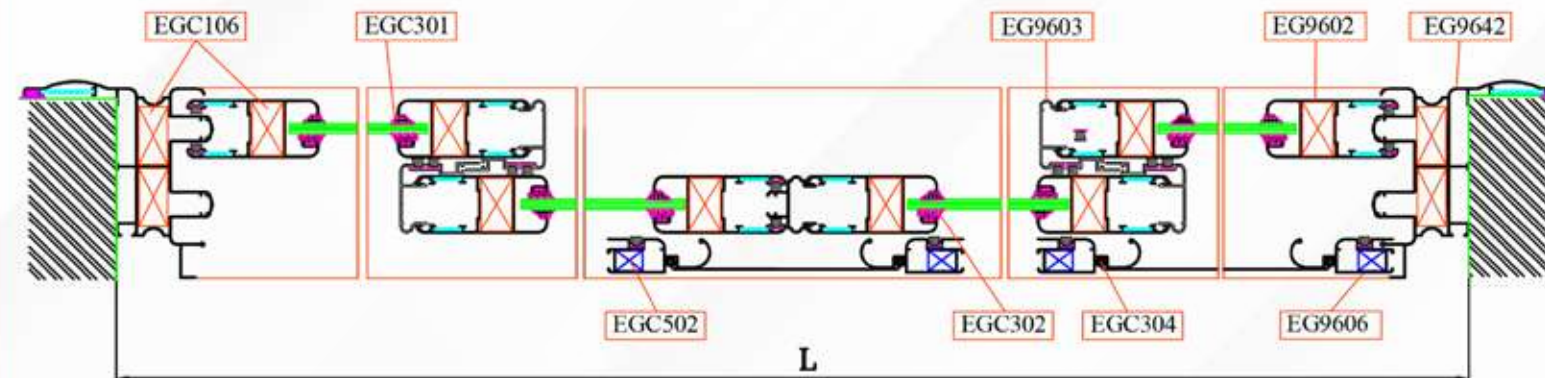
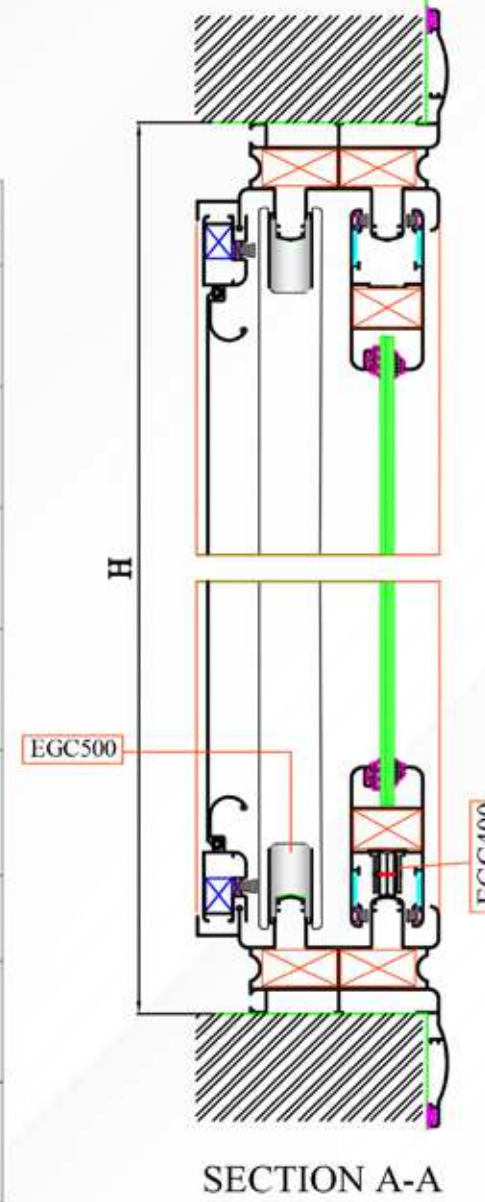

SECTION Z-Z





HINGED EG 48

Cood	DESCRIPTION	PROFILE	WEIGHT Kg/ml.
EG4822	FRAME		0.970
EG4823	FRAME		0.970
EG4879	FRAME		0.907
EG4801	FRAME		0.840
EG4800	FRAME		0.855
EG4805	FRAME		0.775
EG4815	T PROFILE (M)		0.907
EG4816	T PROFILE (M)		1.248
EG4817	KICK PLATE		

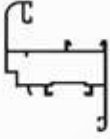
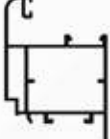
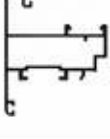
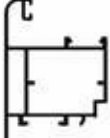
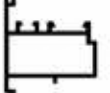

HINGED EG 48

Cood	DESCRIPTION	PROFILE	WEIGHT Kg/ml.
EG 4807	LEAF		0.850
EG4808	LEAF		1.090
EG4879	LEAF		0.850
EG4889	LEAF		1.090
EG4809	FRAME		0.616
EG4811	GLASS HOLDER FOR SINGLE GLASS		0.224
EG4813	GLASS HOLDER FOR DOUBL GLASS		0.194



HINGED EG 48

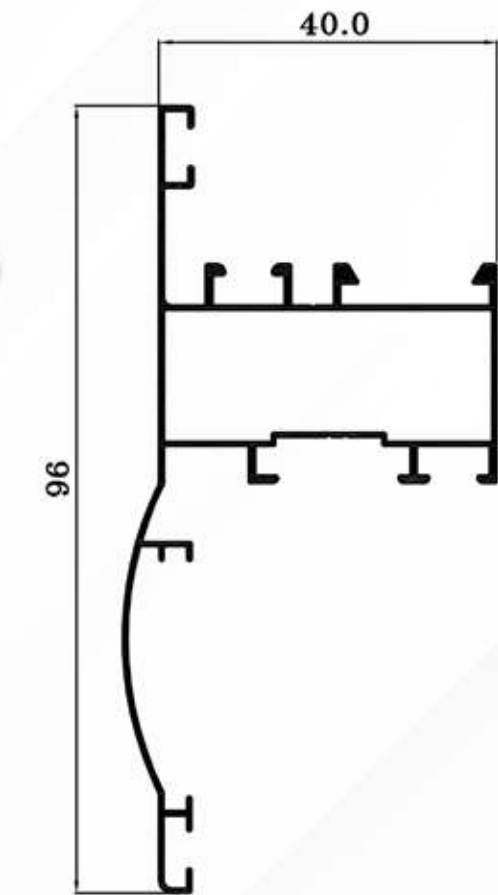

EG4823 0.970 Kg/ml.

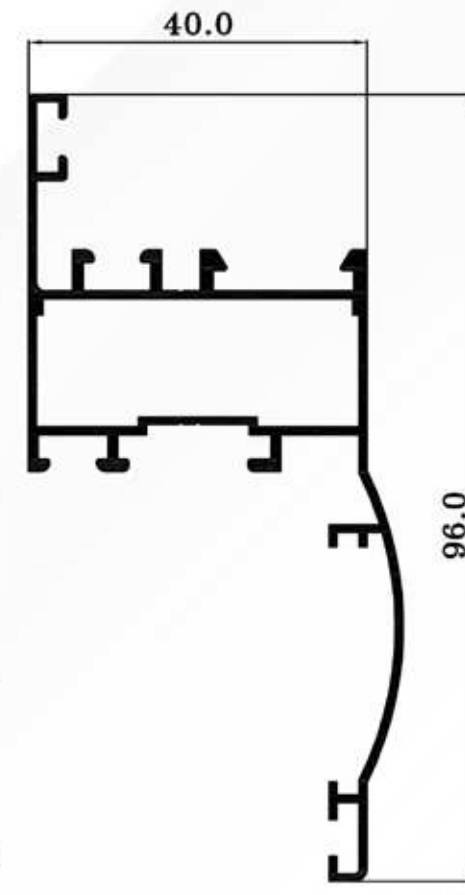

EG4822 0.970 Kg/ml.

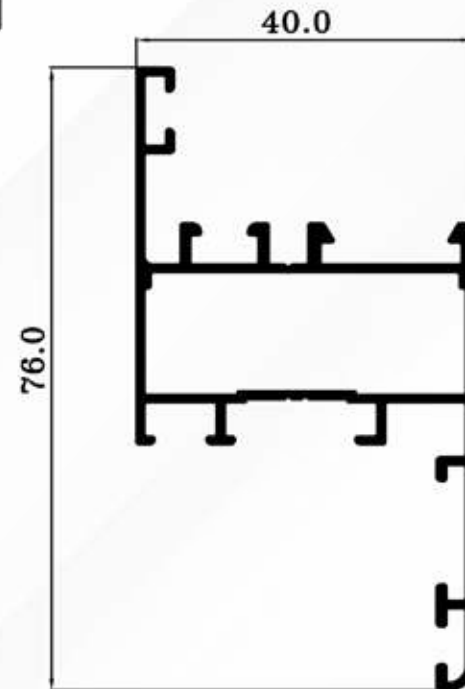

EG4801 0.840 Kg/ml.

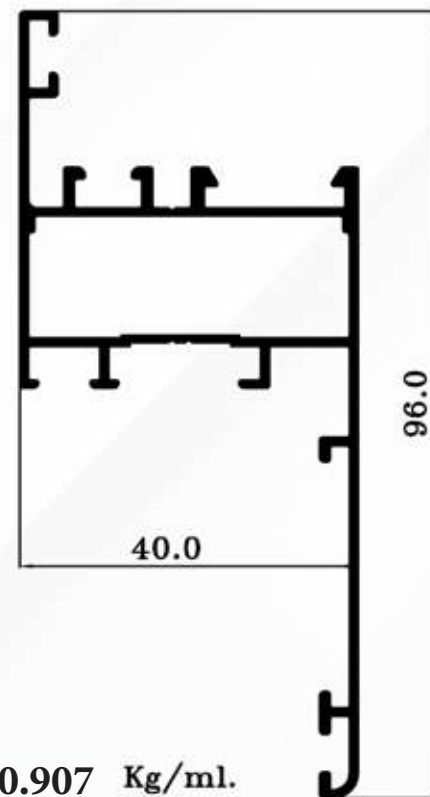

0.907 Kg/ml.

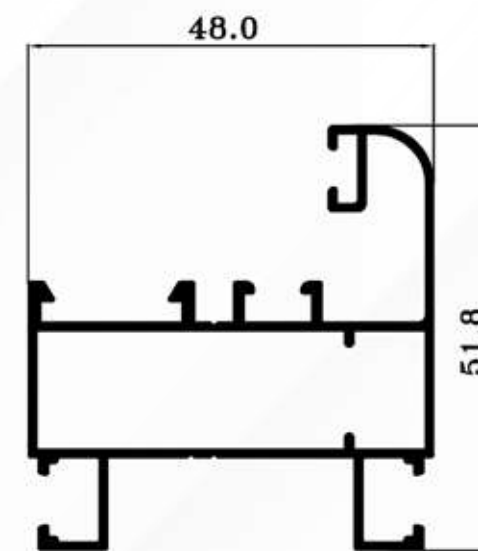

EG4800 0.855 Kg/ml.



HINGED EG 48

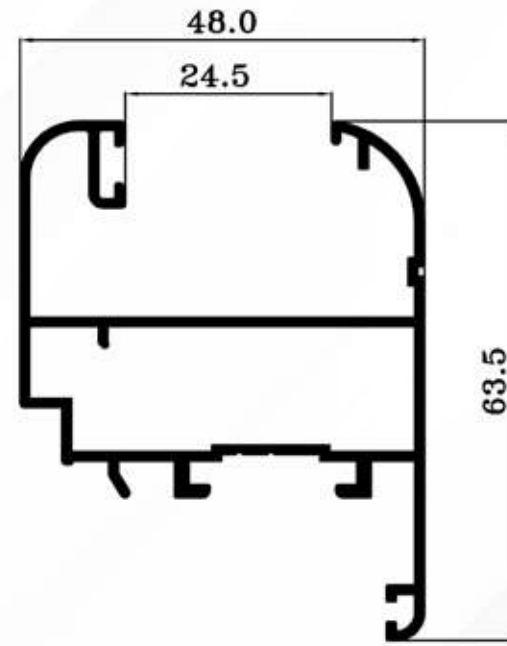

EG4830 0.870 Kg/ml.

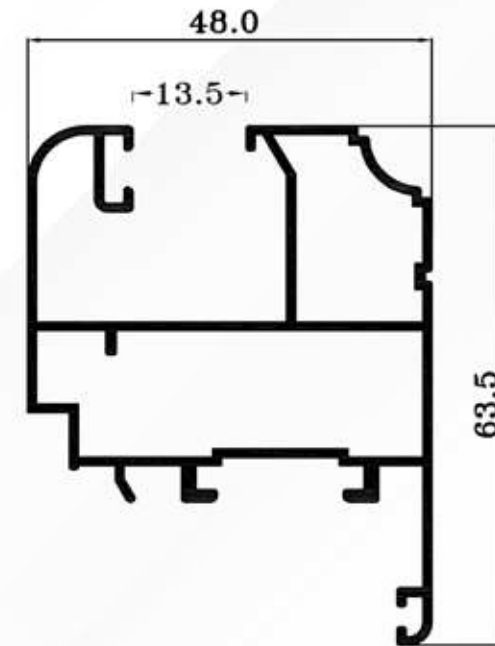

EG4820 0.994 Kg/ml.

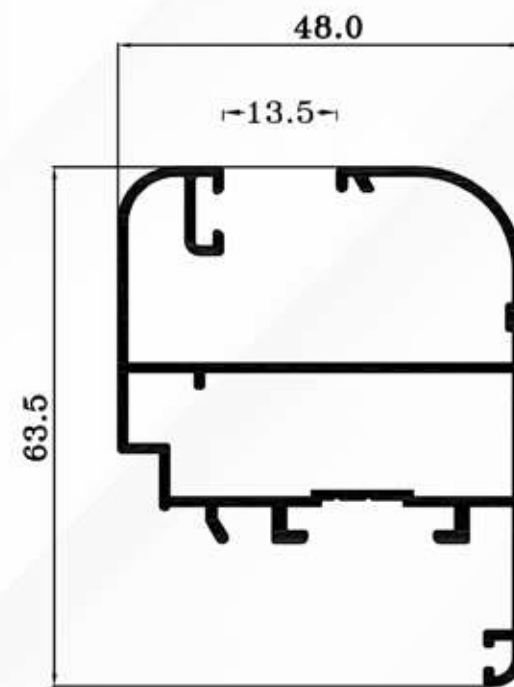

EG4810 0.907 Kg/ml.

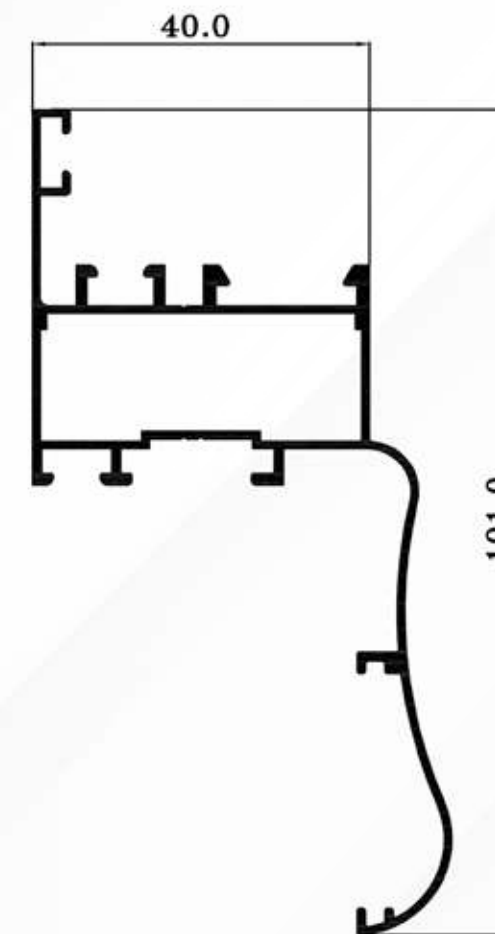

EG4862 Kg/ml.



HINGED EG 48

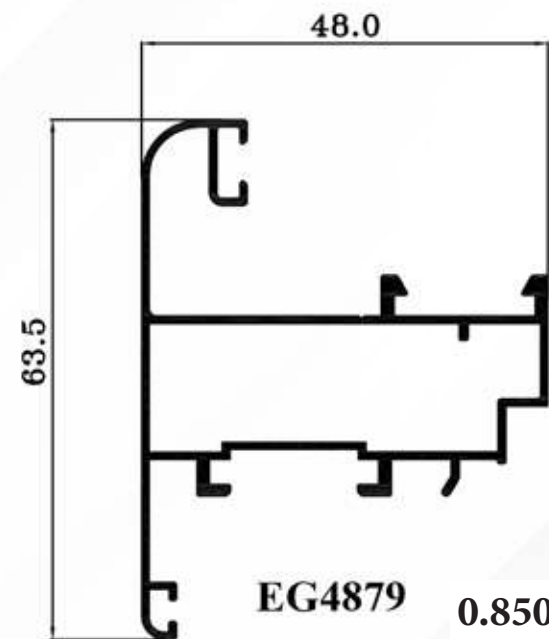

EG4879 0.850 Kg/ml.

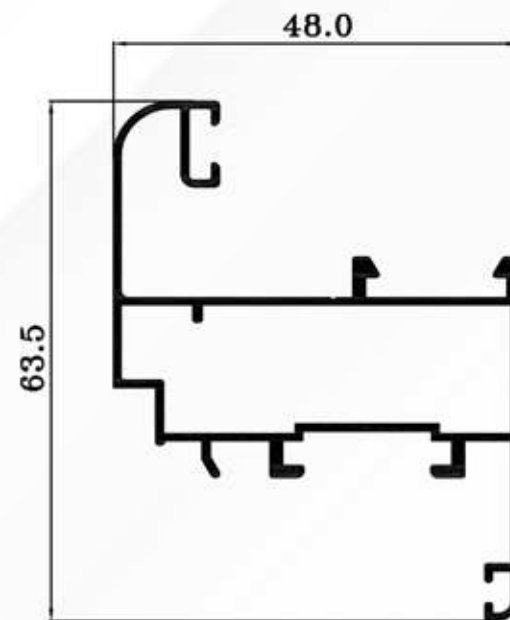

EG4807 0.850 Kg/ml.

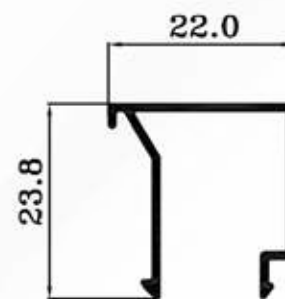

EG4811 0.224 Kg/ml.

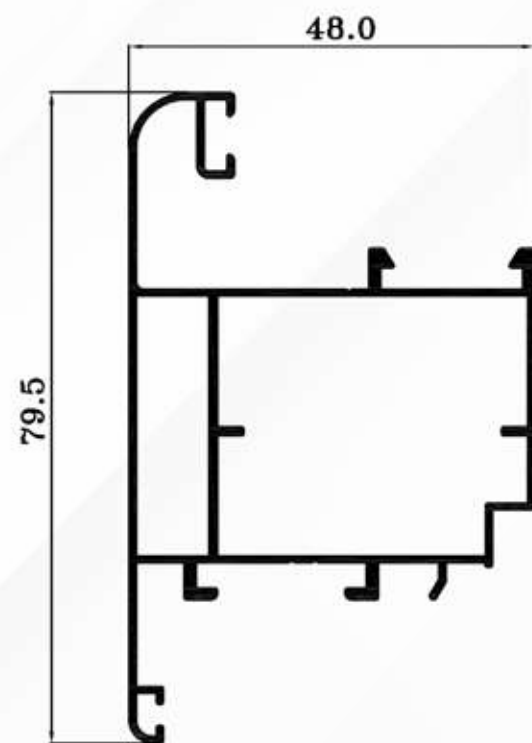

EG4889 1.090 Kg/ml.

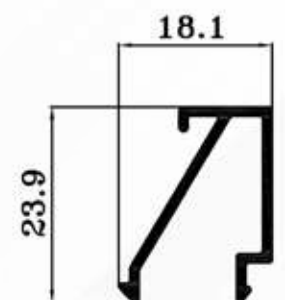

EG4813 0.194 Kg/ml.

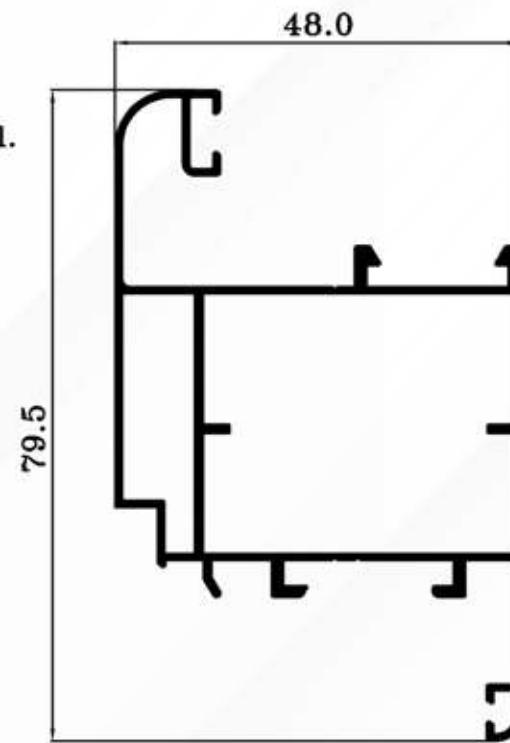

EG4808 Kg/ml.



HINGED EG 48

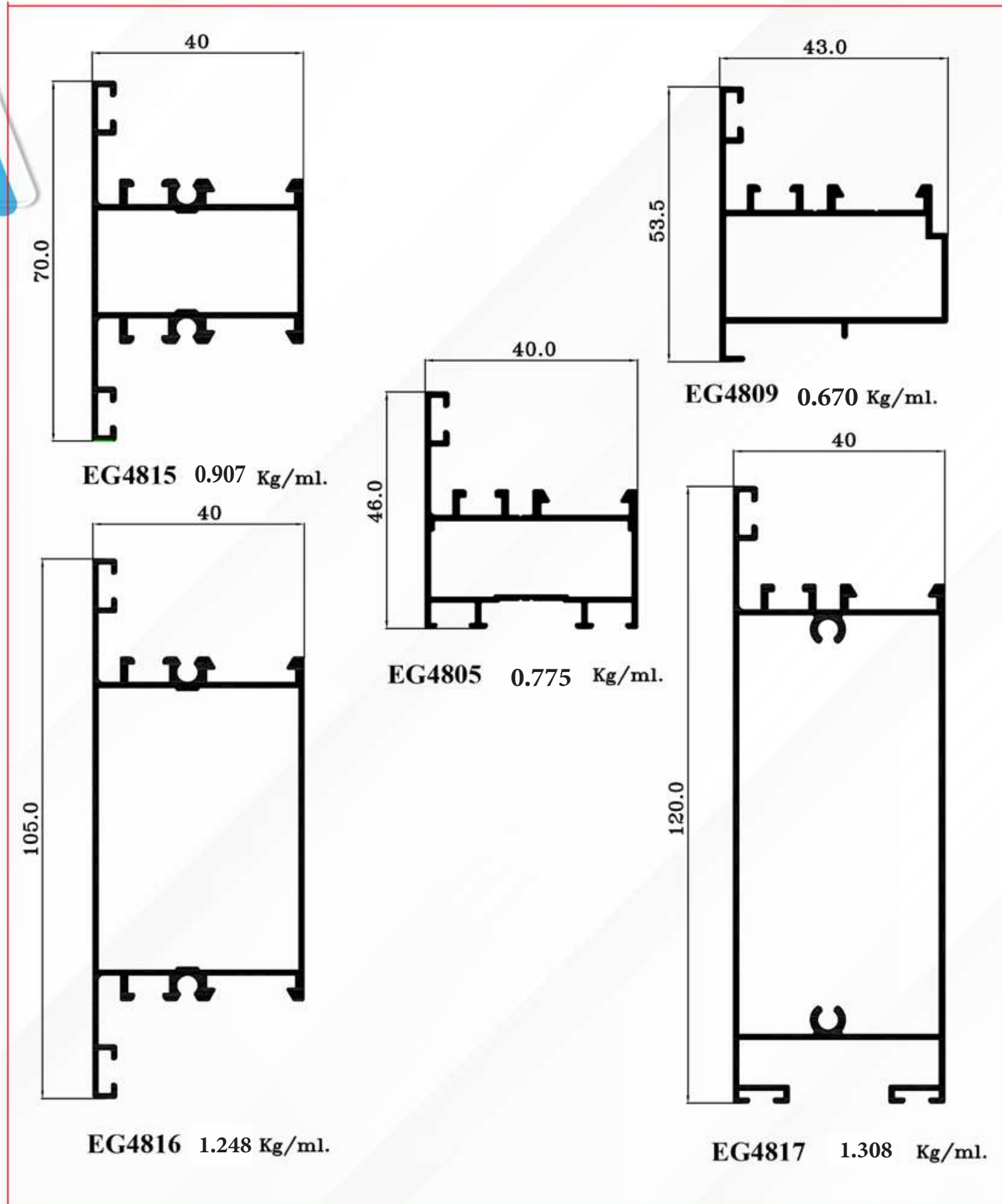



HINGED EG 48

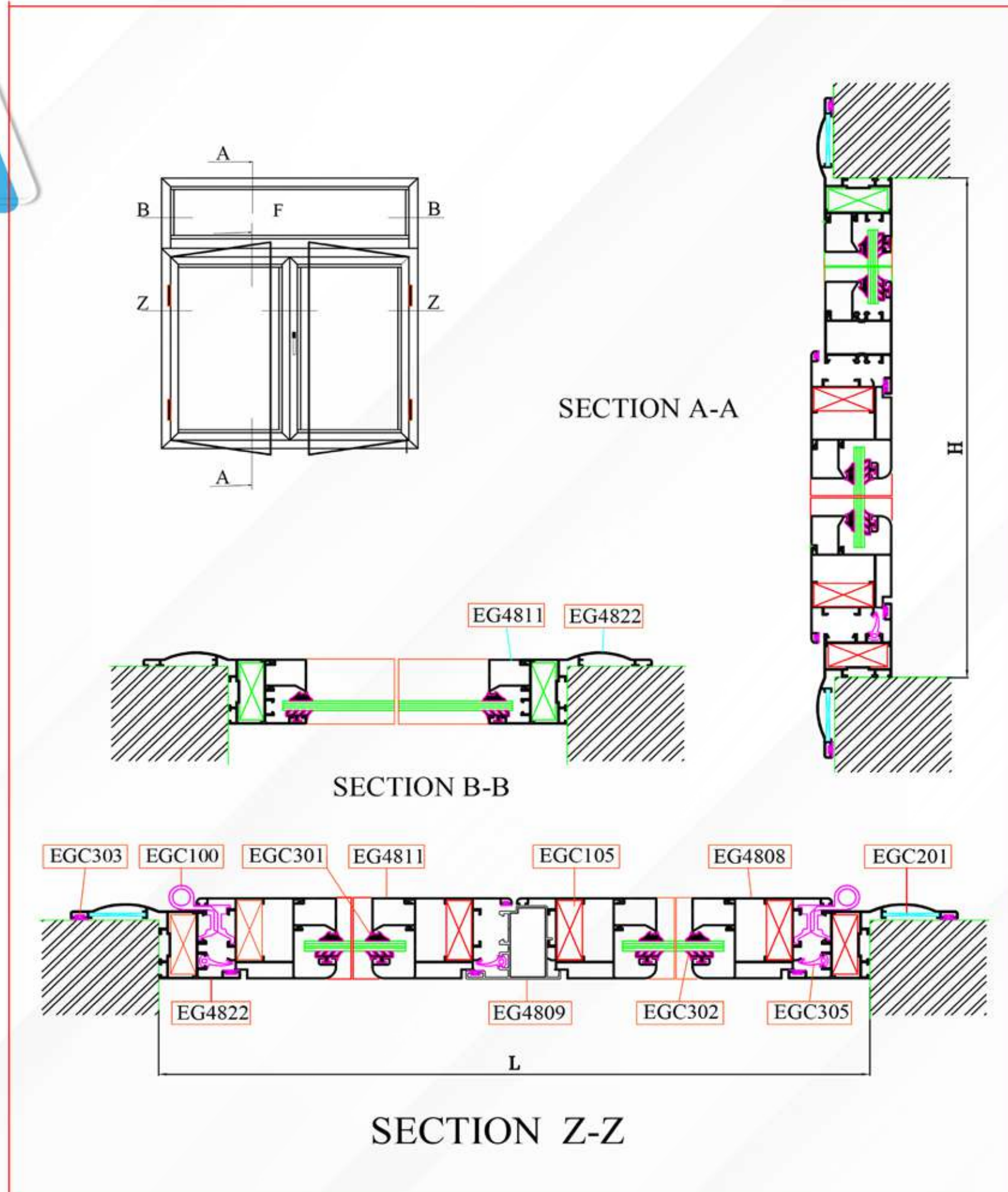



HINGED EG 48

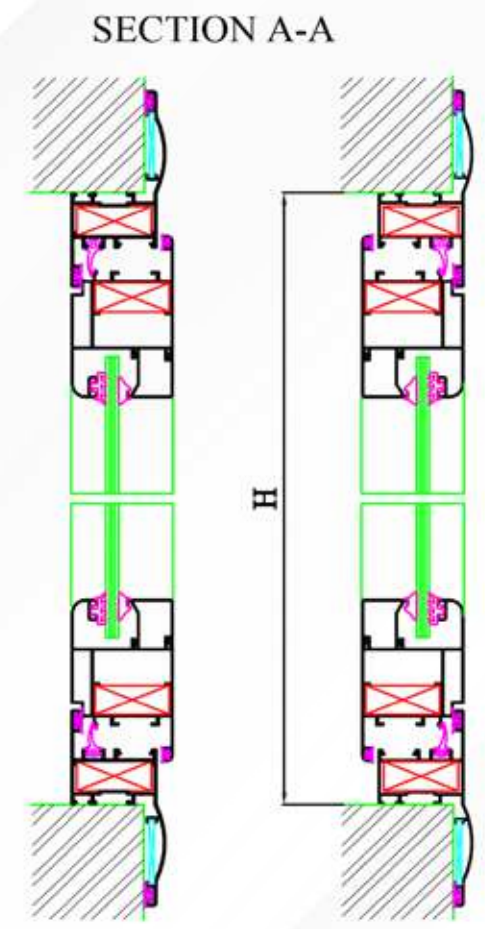
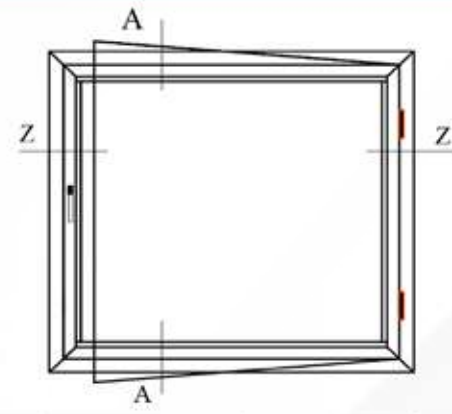

PROFILE No.	QTY.	CUTTING LENGTH (C.m)	CUTTING ANGLE	PROFILE DWG.
EG4808	2	L-4.2	45	
EG4808	2	H-4.2	45	
EG4811	2	L-12.1	90	
EG4811	2	H-12.1	90	
EG4823	2	L+10	45	
EG4823	2	H+10	45	

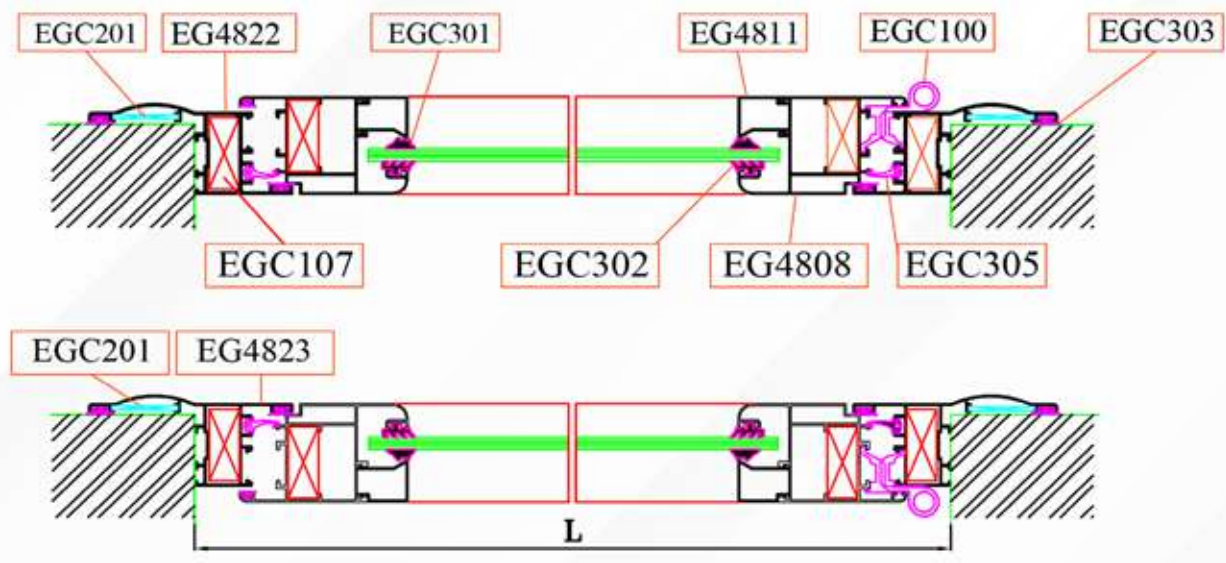

SECTION Z-Z



HINGED EG 48

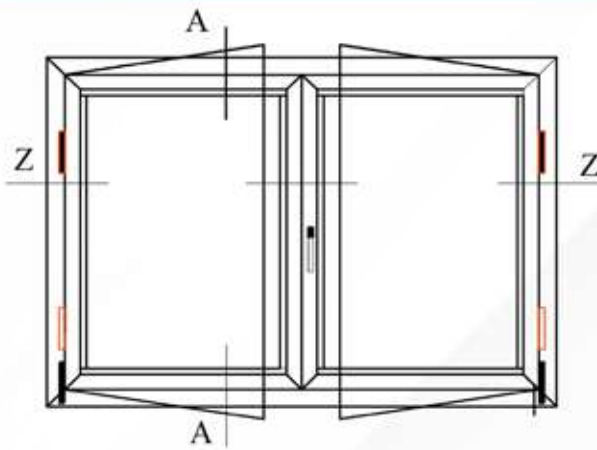

SECTION A-A

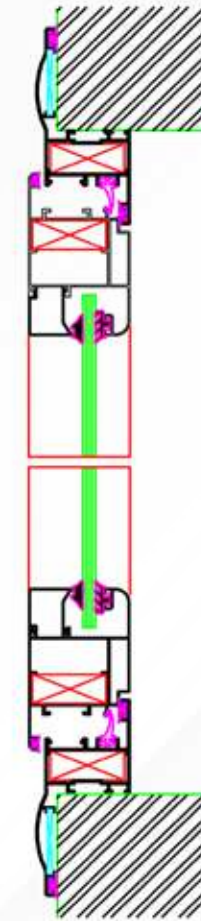



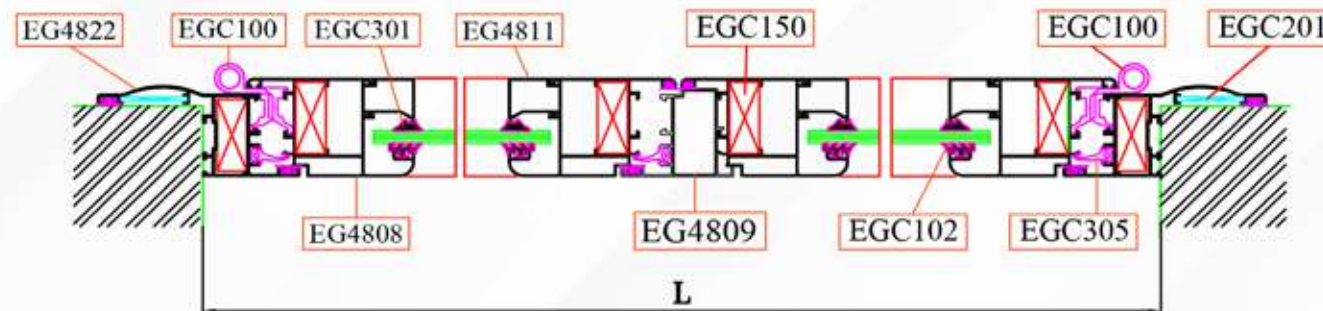







PROFILE No.	QTY.	CUTTING LENGTH (C.m)	CUTTING ANGLE	PROFILE DWG.
EG4808	4	L-4.5/2	45	
EG4808	4	H-4.2	45	
EG4811	4	L-20.3/2	90	
EG4811	4	H-12.1	90	
EG4823	2	L+10	45	
	2	H+10	45	
EG4809	1	H-5.4	90	



SECTION Z-Z



HINGED EG 48

Cood	DESCRIPTION	SHAPA SECTION
EGC303	GLAZING GASKET	
EGC302	GLAZING GASKET	
EGC301	GLAZING GASKET	
EGC305	CENTRAL GASKET	
EGC103	BRUSH	
EGC400	SINGLE ROLLER	
EGC502	SCREW CORNER	
EGC105	ANGLE BRACKET	
EGC106	ANGLE BRACKET	
EGC107	ANGLE BRACKET	
EGC100	HINGE	

